



UDOR[®]
USA

World Leader in Diaphragm and Plunger Pumps



Misting, Cooling and Fogging Applications
Plunger Pumps and Accessories

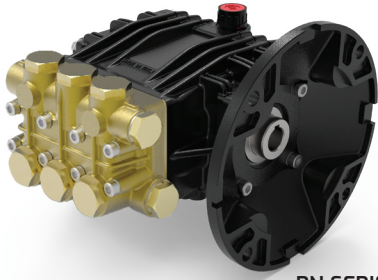

PN SERIES
0.5-4.0 GPM
UP TO 2465 PSI
Shown with NEMA 56C Flange
for 5/8" Shaft Electric Motors
Other drive options available

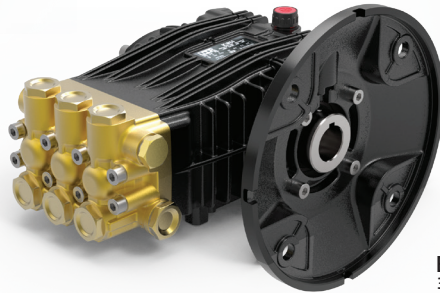

B SERIES
3.4-6.0 GPM
UP TO 2900 PSI
Shown NEMA 182/184 TC Flange
for 1-1/8" Shaft Electric Motors
Other drive options available

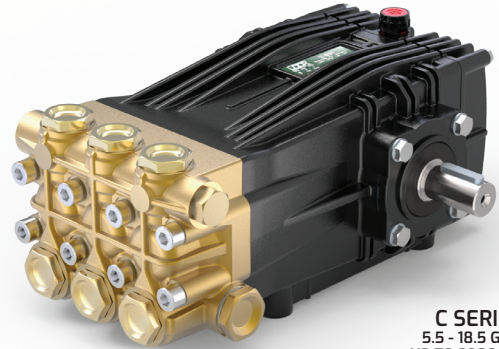

C SERIES
5.5 - 18.5 GPM
UP TO 2900 PSI
Shown 24mm Solid Keyed Shaft
Other drive options available

High Pressure Misting and Fogging *Efficient indoor and outdoor cooling through evaporation...*

High-pressure misting systems can provide a temperature drop of up to 30 degrees F. High pressure water is pumped through atomizing nozzles to produce a fine mist that evaporates immediately, cooling the surrounding area.

High-pressure misting and fogging systems offer economical and efficient cooling and humidity control. Common applications include:

- Cooling for poultry, dairy and beef operations
- Cooling at stadiums, amusement parks, fairs and other crowded gatherings
- Patio and deck misting at pools, hotels, resorts and restaurants
- Cooling public transit stations for buses and trains
- Greenhouse temperature control

With worldwide, field-proven dependability, UDOR USA provides the best value for misting and fogging applications.



Patios and Outdoor Dining



Dairy Cattle Barns

Plunger Pumps



Stainless Steel Series Pumps

Engineered for food processing environments or where harsh chemicals are injected into the mist.

UDOR USA's stainless steel pumps feature:

- 316 Stainless Steel Manifolds
- 316 Stainless Steel Valves
- 316 Stainless Steel Plunger Rods & Nuts
- 304 Stainless Steel Exterior Bolts
- Solid Ceramic Plungers
- PTFE Style Packings
- Max Fluid Temp, 160°F

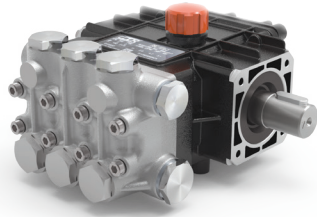

PS SERIES
1.5-3.4 GPM
UP TO 2175 PSI
Shown 24mm Solid Keyed Shaft
1450 RPM

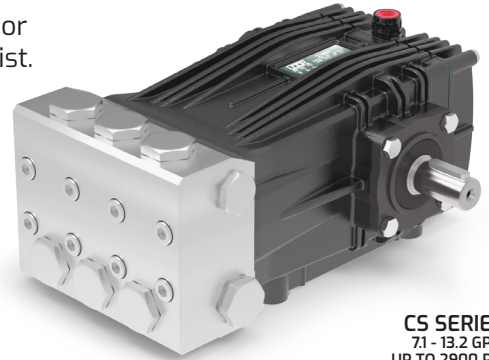

CS SERIES
7.1 - 13.2 GPM
UP TO 2900 PSI
Shown 24mm Solid Keyed Shaft
1450 RPM

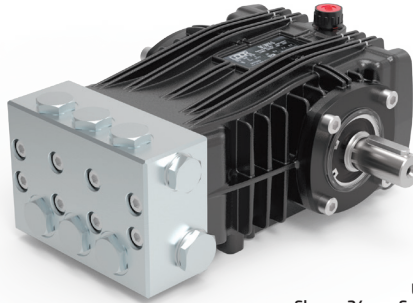

BS SERIES
4.0 - 5.5 GPM
UP TO 2900 PSI
Shown 24mm Solid Keyed Shaft
1450 RPM

UNLOADERS and RELIEF VALVES ▾



UB130
5.0 GPM @ 2300 PSI
3/8" M Inlet
3/8" M Outlet
3/8" F Bypass



UD7100
10.5 GPM @ 1500 PSI
3/8" F Inlet
3/8" F Outlet
3/8" F Bypass



UB150SS
21.0 GPM @ 2320 PSI
1/2" F Inlet
1/2" F Outlet
1/2" F Bypass



UD555SS
7.0 GPM @ 2000 PSI
3/8" M Inlet
3/8" F Bypass
Stainless Steel



UD550
7.0 GPM @ 1000 PSI
3/8" M Inlet
3/8" F Bypass



UD555FT
7.0 GPM @ 2000 PSI
3/8" F Inlet
3/8" F Outlet
3/8" F Bypass

SPRAY GUNS ▾

Turbo Spray Guns

15 GPM. Up to 850 PSI.



Turbo, Turbine & Long Range Spray Guns feature adjustable spray pattern from a straight stream to a fine cone mist..

MORE ACCESSORIES ▾



POLYPROPYLENE INLET FILTERS

- 1", 1-1/4" and 1-1/2" Models
- 32 Mesh - for Plunger Pump Applications
- 16 Mesh - for Diaphragm Pump Applications



UDOR LUBE / UDOR LUBE SYNTHETIC

SAE 40W non-detergent lubricant. Specially formulated for use in Udor diaphragm & plunger pumps.

- Non-Detergent. Non-Foaming
- Rust Inhibitors
- Anti-wear Agents
- Resists Breakdown Due to Oxidation
- Synthetic Oil Recommended for Cold Weather Uses

Plunger Pump Features

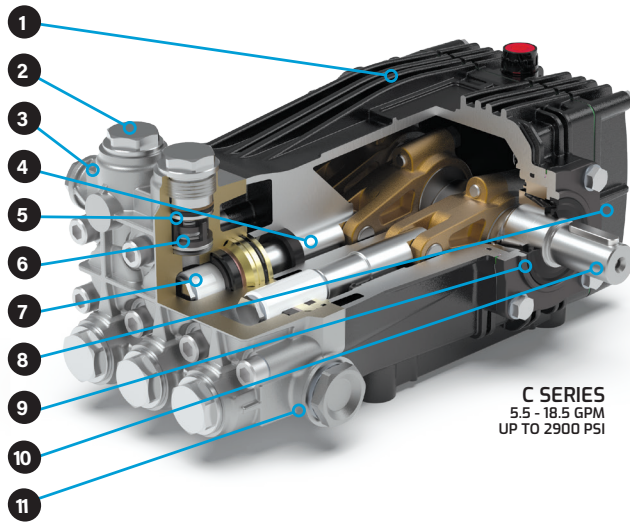

- 1 Anodized Die-Cast Aluminum Crankcase
- 2 Large Diameter Stainless Steel Valve Caps with Increased Thread Depth
- 3 Heavy Duty Solid Brass Manifold
- 4 Stainless Steel Stepped Plunger Guide for Increased Seal Life
- 5 Bottom Mount O-Ring and Back-Up Ring to Prevent Thread Damage
- 6 Stainless Steel Conical Valve Assembly for Increased Efficiency
- 7 High-Polished Solid Ceramic Plungers
- 8 Deeper Back Cover for Increased Oil Capacity
- 9 Heavy Duty Tapered Roller Bearings
- 10 Heat Treated Crankshaft
- 11 Reinforcing Ring on Inlet and Discharge Ports

More Misting & Fogging Applications

Other common high-pressure misting and fogging system applications include:

- Temperature, humidity and odor control for cannabis production
- Odor control at compost and landfill facilities
- Dust suppression at construction and mining sites

Cannabis Misting and Odor Control



Landfill Dust and Odor Control



UDOR[®]
USA

World Leader in
Diaphragm and Plunger Pumps

6180 140th Avenue NW
Ramsey, MN 55303

Ph: 651-785-0666
Fax: 800-732-2670

www.udorusa.com
sales@udorusa.com

Scan this QR Code
to Visit www.udorusa.com



FLYER
MS225A