

3-Cylinder, Low-Pressure Diaphragm Pumps

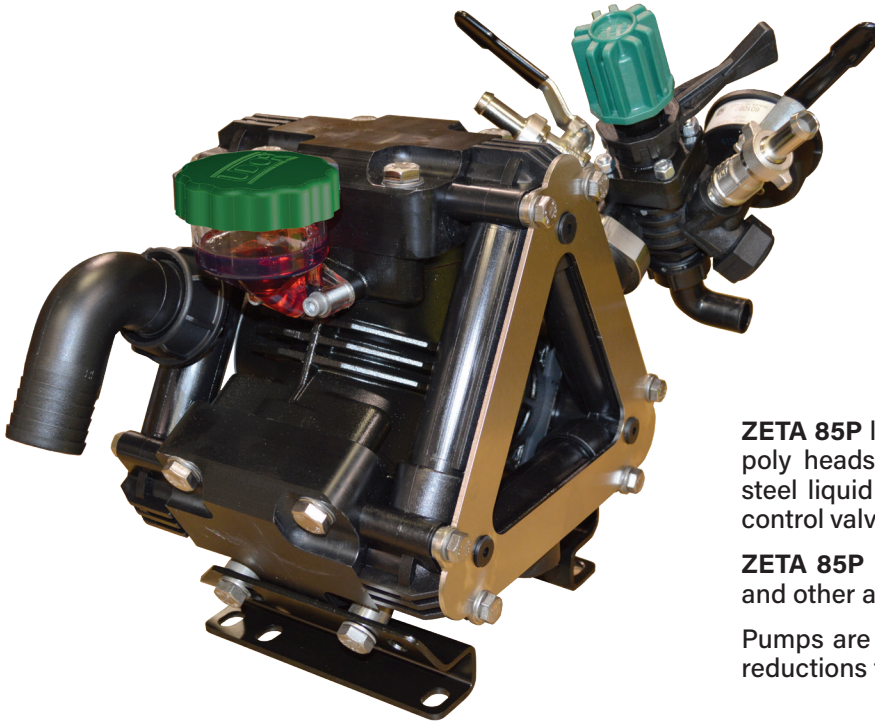

ZETA 85P low pressure 3-cylinder diaphragm pumps have poly heads, externally mounted manifolds and stainless-steel liquid handling parts and hardware components. A control valve with pressure gauge is standard on all models.

ZETA 85P pumps are excellent for the soft wash industry and other aggressive fluid applications.

Pumps are available with Universal VA Drive Face or gear reductions for 4 to 6.5 HP gas engines.

Model	GPM	l/min	PSI	bar	RPM	Drive Configuration	Weight
ZETA 85P VA	22.0	85	300	20	550	Universal VA Drive Face.	29 LBS
ZETA 85P VAGR3/4	22.0	85	300	20	550	Gear Reduction for 3/4" Shaft Gas Engine, 4-6.5 HP	36 LBS

Specifications	ZETA 85P	Description	Part #
Inlet Port	1-1/2" Hose Barb	Diaphragm Kit - GREENTECH	6062.97
Outlet Ports - Valve	(2) 1/2" Hose Barb	Diaphragm Bolt & Washer Kit	6062.48
Bypass	3/4" Hose Barb	Valve Kit	6062.H1
Piston Diameter	60.0mm	Regulator Repair Kit	6062.A9
Crankshaft Stroke/Code	18.0mm / A	Complete Repair Kit	8700.63CK
Dims. - Pump Only	11"L x 11"W x 12"H		
- GR Version	16"L x 11"W x 12"H		

Lubrication: Requires 39 oz. of Udor Lube 40W Premium Pump Oil.
Alternate Oil: 30W non-detergent or 15W-40 non-detergent oil.



Maximum Flow	22 GPM / 85 lpm
Maximum Pressure	300 PSI / 20 bar
Maximum RPM	550 RPM
Inlet Port - Hose Barb	1-1/2" HB
Outlet Ports - Hose Barb, Valve	(2) 1/2" HB
Bypass - Hose Barb	3/4" HB
Dimensions - ZETA 85P GR	16"L x 11"W x 12"H
Weight - ZETA 85P GR	36 lbs

Lubrication: Requires 39 oz. of Udor Lube 40W Premium Pump Oil.
Alternate Oil: 30W non-detergent or 15W-40 non-detergent oil.

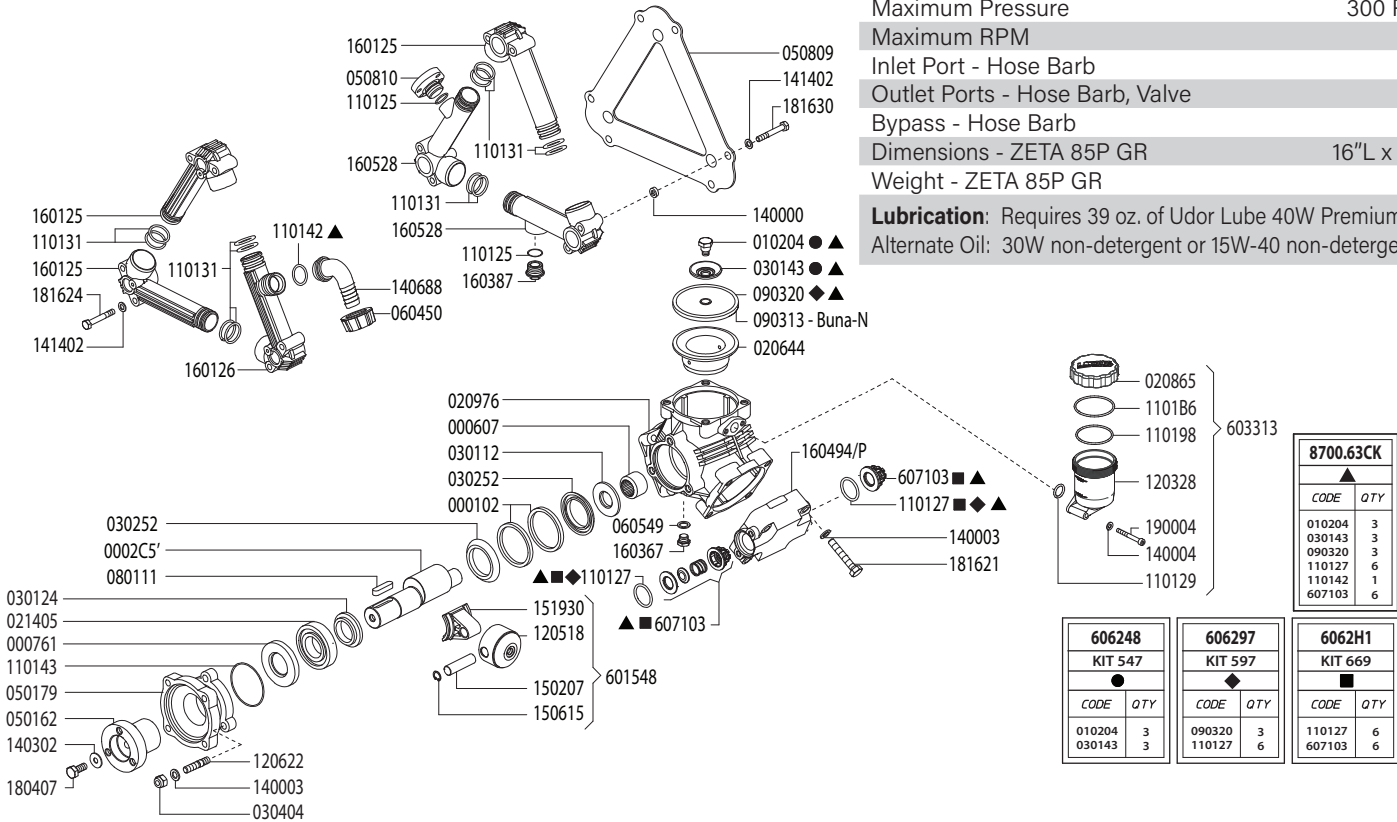

Revised 8-29-2024

Part #	Description	Qty	Part #	Description	Qty
0001.02	RETAINER RING	2	1206.22	STUD M10X46	3
0002.C5	CRANKSHAFT	1	1400.00	DISCHARGE MANIFOLD SPACER S.S.	6
0006.07	BEARING	1	1400.03	HEAD BOLT WASHER S.S.	15
0007.61	SEAL	1	1400.04	WASHER M8 S.S.	2
0102.04	DIAPHRAGM BOLT S.S. ●▲	3	1403.02	WASHER M10	1
0206.44	PISTON SLEEVE	3	1406.88	SUCTION ELBOW 1-1/2"	1
0208.65	OIL RESERVIOR CAP	1	1414.02	MANIFOLD WASHER S.S.	12
0209.76	CRANKCASE	1	1502.07	CONNECTING ROD PIN 15X54	3
0214.05	BALL BEARING D35	1	1506.15	SNAP RING	6
0301.12	BEARING DISC D25	1	1519.30	CONNECTING ROD	3
0301.24	BEARING DISC D35	1	1601.25	INLET/OUTLET MANIFOLD TUBE	3
0301.43	DIAPHRAGM WASHER ●▲	3	1601.26	SUCTION MANIFOLD TUBE G1-1/2" M	1
0302.52	ROD SPACER	2	1603.67	OIL PLUG G1/4	1
0304.04	NUT	3	1603.87	MANIFOLD PLUG G3/4	2
0501.62	ADAPTER - VA	1	1604.94/P	HEAD - POLY	3
0501.79	FLANGE - VA	1	1605.28	DISCHARGE MANIFOLD TUBE G3/4" F	2
0508.09	DISCHARGE PLATE S.S.	1	1804.07	HEX BOLT M10X25	1
0508.10	REGULATOR ADAPTER S.S.	1	1816.21	HEAD BOLT S.S.	12
0604.50	BARB NUT	1	1816.24	SUCTION MANIFOLD BOLT S.S.	6
0605.49	OIL PLUG GASKET	1	1816.30	DISCHARGE MANIFOLD BOLT S.S.	6
0801.11	KEY 10X8X40	1	1900.04	ALLEN BOLT M6X50 S.S.	2
0903.13	PISTON DIAPHRAGM 100mm,BUNA-N	3	6015.48	PISTON / ROD ASSEMBLY D60	3
0903.20	PISTON DIAPHRAGM 100mm,GREENTECH ◆▲	3	6033.13	OIL RESERVOIR ASSEMBLY	1
1101.25	O-RING - PLUG & ADAPTER	2	6071.03	VALVE ASSEMBLY 316SS W/O O-RING ■▲	6
1101.27	O-RING - VALVE ◆■▲	6	6062.48	DIAPHRAGM WASHER/BOLT (KIT 547)	1
1101.29	O-RING - OIL RESERVIOR	1	6062.97	DIAPHRAGM KIT - GREENTECH (KIT 597)	1
1101.31	O-RING - MANIFOLD	12	6062.H1	INLET/OUTLET VALVE KIT (KIT 669)	1
1101.42	O-RING - INLET BARB▲	1	8700.63CK	COMPLETE REPAIR KIT	1
1101.43	O-RING - FLANGE	1			
1101.98	O-RING - OIL RESERVIOR	1			
1101.B6	O-RING - OIL RESERVIOR	1			
1203.28	OIL RESERVOIR	1			
1205.18	ALUMINUM PISTON D60	3			

- Parts in 6062.48 (Kit 547)
- ◆ Parts in 6062.97 (Kit 597).
- Parts in 6062.H1 (Kit 669).
- ▲ Parts in 8700.63CK (Complete Repair Kit)

**GAS ENGINE GEAR REDUCTION FOR
KAPPA-55, ZETA-40/85/120 DIAPHRAGM PUMPS
on GAS ENGINES with 3/4" SHAFTS
REQUIRES 16 OZ. 90W GEAR LUBE**

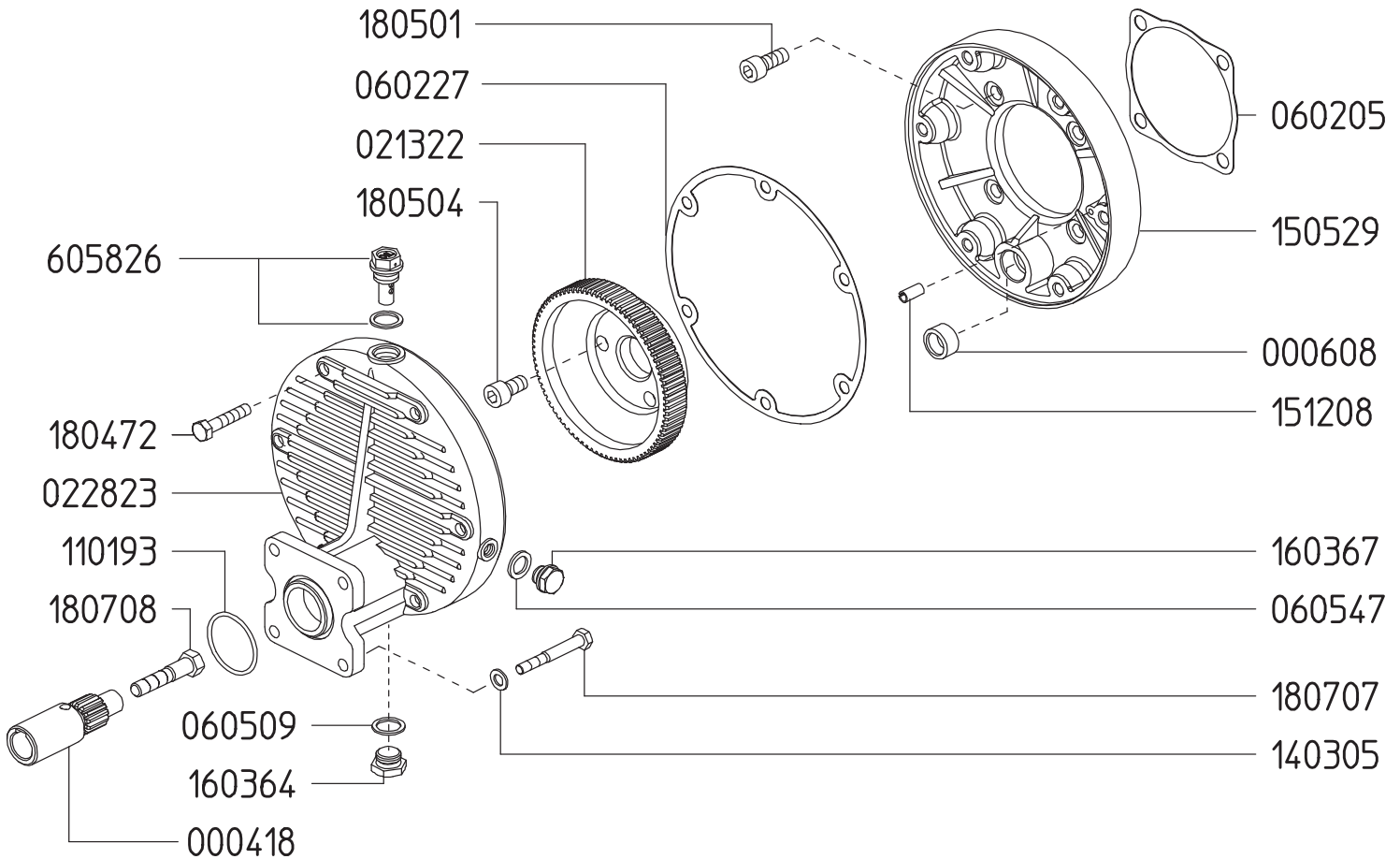

Revised 8-29-2024

Part #	Description	Qty	Part #	Description	Qty
0004.18	GEAR SHAFT - 3/4"	1	1505.29	GEAR CASE - PUMP	1
0006.08	BEARING	1	1512.08	ALIGNMENT PIN	1
0213.22	PUMP GEAR - VA	1	1603.64	OIL PLUG G3/8	1
0228.23	GEAR CASE - ENGINE	1	1603.67	OIL PLUG G1/4	1
0602.05	GASKET	1	1804.72	HEX BOLT M8X50	6
0602.27	GASKET	1	1805.01	ALLEN BOLT M10X25	4
0605.09	GASKET - ALUMINUM	1	1805.04	ALLEN BOLT M10X20	3
0605.47	GASKET - ALUMINUM	1	1807.07	HEX BOLT 5/16 X 1"	4
1101.93	O-RING	1	1807.08	HEX BOLT 5/16 X 2-1/4"	1
1403.05	WASHER	4	6058.26	VENTED OIL CAP	1

Adjustable Pressure Regulator

Maximum Flow	27.0 GPM / 102 lpm
Maximum Pressure	350 PSI / 24 bar
Inlet Port - Hose Barb	-
Outlet Ports - Hose Barb, Valve	(2) 1/2" HB
Bypass - Hose Barb	3/4" HB

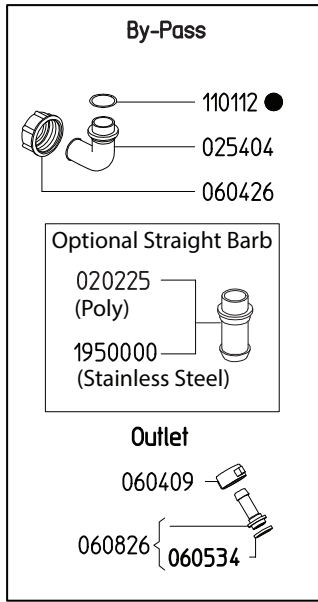
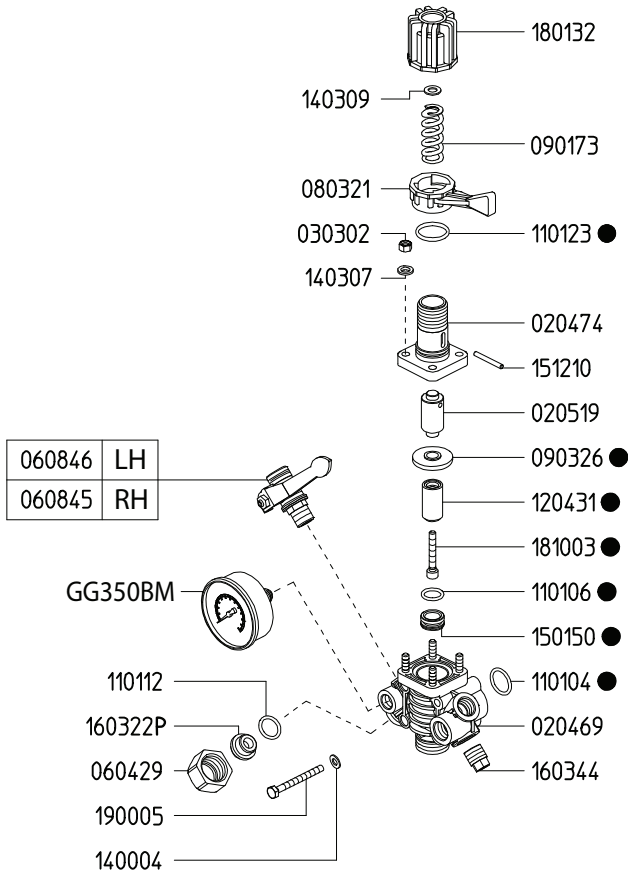

6062A9	
KIT 608	
CODE	QTY
090326	1
110104	1
110106	1
110112	1
110123	1
120431	1
150150	1
181003	1

Revised 8-29-2024

Part #	Description	Qty
0202.25	BYPASS HOSE BARB - STRAIGHT (OPTIONAL)	1
0204.69	BODY	1
0204.70	BODY	1
0205.19	CYLINDER	1
0254.04	BYPASS HOSE BARB - ELBOW	1
0303.02	NUT	4
0604.09	BARB NUT	2
0604.26	BYPASS BARB NUT	1
0604.29	NUT	1
0605.34	GASKET	2
0608.26	1/2" HOSE BARB W/GASKET	2
0608.45	BALL VALVE - RIGHT	1
0608.46	BALL VALVE - LEFT	1
0803.21	LEVER	1
0901.73	SPRING (LP 300 PSI)	1
0903.26	DIAPHRAGM ●	1
0904.37	GG350BM - LOW PRESSURE GAUGE	1

Part #	Description	Qty
1101.04	O-RING ●	1
1101.06	O-RING ●	1
1101.12	O-RING ●	2
1101.23	O-RING ●	1
1204.31	POPPET ●	1
1400.04	WASHER S.S.	6
1501.50	SEAT ●	1
1512.10	PIN	1
1603.22P	PLUG - POLY	1
1603.44	PLUG	1
1801.32	ADJUSTMENT KNOB	1
1810.03	STAINLESS STEEL BOLT ●	1
1900.05	STAINLESS STEEL BOLT	2
19500.00	BYPASS HOSE BARB - STRAIGHT, SS (OPTIONAL)	1
6062.A9	REPAIR KIT FOR 6010.9X CONTROL UNIT (KIT 608)	

● Parts Included in Repair Kit #6062.A9 (KIT 608)

The control unit features a manual dump valve, pressure control knob, glycerine filled pressure gauge, and two ball valve discharge ports.

1. Before operating or re-operating the pump move lever (0803.21) to the dump position (Right) so the pump will start at zero pressure. (Failure to do so will void the pump warranty.)
2. Turn pressure adjustment knob (1801.32) counter clockwise to relieve spring tension. This step only applies to the initial start up and is not necessary in daily operation of pump.
3. Start unit and let run until air is evacuated from the system.
4. Move lever (0803.21) to the pressure position (Left) open spray gun or spray boom and turn the pressure adjustment knob (1801.32) clockwise until desired operating pressure is achieved.

ZETA 40P/85P DIMENSIONS

All Dimensions are WITHOUT Control Unit or Regulator

Dimensional Drawings are Shown in Millimeters. To Convert to Inches, Multiply Dimension x 0.03937

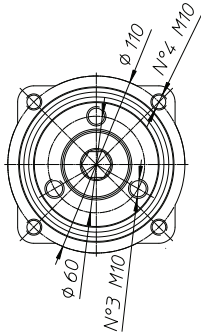
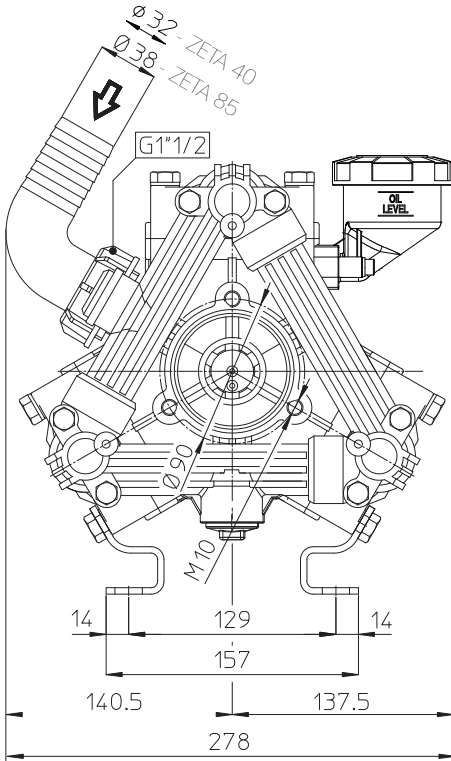

Specifications	ZETA 40P	ZETA 85P
Inlet Port - Hose Barb	1-1/4" HB	1-1/2" HB
Outlet Ports - Hose Barb, Valve	(2) 1/2" HB	(2) 1/2" HB
Bypass - Hose Barb	3/4" HB	3/4" HB
Dimensions - Pump Only		11"L x 11"W x 12"H
- GR Version		16"L x 11"W x 12"H
Diaphragm Material	GREENTECH (Std) Buna-N (Opt)	

Lubrication: Requires 39 oz. of Udor Lube 40W Premium Pump Oil. Alternate Oil: 30W non-detergent or 15W-40 non-detergent oil.

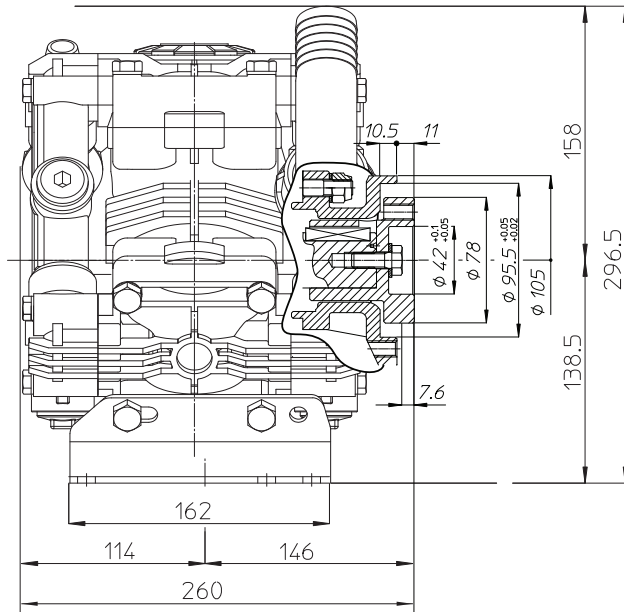

VA Universal Drive Face Detail

Dimensional Drawings are Shown in Millimeters. To Convert to Inches, Multiply Dimension x 0.03937

TORQUE SPECS

Ref.	Description	Ft./lb.	Nm
1	Diaphragm Bolts (Use Loctite 243)	18	25
2	Head Bolts	12	16
3	Pulsation Dampener Bolts	18	25
4	Oil Cup Bolts	6	8
5	Manifold Bolts (Plastic)	8	11

