

4-Cylinder, High-Pressure Diaphragm Pumps



DELTA 170 4-cylinder, high pressure diaphragm pumps are internally manifolded with anodized aluminum construction and anodized aluminum and stainless steel liquid handling parts. Includes mounting rails and 6005.05 control unit with pressure gauge.

DELTA 170 pumps are excellent choices for various horticultural, agricultural, lawn care, nursery, pest control and turf spraying applications. They are also effectively used for aircraft de-icing, hydrostatic testing and cleaning applications.

Model	GPM	l/min	PSI	bar	RPM	Drive Configuration	Weight
DELTA 170 TS2C	47.3	179.5	725	49	550	1-3/8" 6-Spline Male PTO Thru-Shaft	110 LBS
DELTA 170 TSMFVA	47.3	179.5	725	49	550	1-3/8" 6-Spline PTO x Universal VA Drive Face	110 LBS
DELTA 170 GR1-1/8	47.3	179.5	725	49	550	Gear Reduction for 1-1/8" Shaft Gas Engines, 24-31 HP	130 LBS
DELTA 170 GR ASSY	47.3	179.5	725	49	550	Pump, Gear Reduction, 31 HP Gas Engine, Base	320 LBS

Specifications	DELTA 170	Description	Part #
Inlet Port	1-1/2" Hose Barb	Diaphragm Kit (GREENTECH)	6062.H7
Outlet Ports	(2) 1/2" Hose Barb	Diaphragm Bolt / Washer Kit	606224
Bypass	1" Hose Barb	Valve Kit	6062.H8
Piston Diameter	75mm	Complete Repair Kit	8700.84CK
Crankshaft Stroke/Code	19.0mm / U		
Dimensions	15.5"L x 21.5"W x 16.5"H		

Lubrication: Requires 66 oz. of Udor Lube 40W Premium Pump Oil.
Alternate Oil: 30W non-detergent or 15W-40 non-detergent oil.



Maximum Flow	47.3 GPM / 179.2 lpm
Maximum Pressure	725 PSI / 50 bar
Maximum RPM	550 RPM
Inlet Port	1-1/2" Hose Barb
Outlet Ports	(2) 1/2" Hose Barb Valve, 3/4" MPT
Bypass	1" Hose Barb
Dimensions	15.5" L x 21.5" W x 16.5" H
Weight	110 lbs

Lubrication: Requires 66 oz. of Udor Lube 40W Premium Pump Oil.
Alternate Oil: 30W non-detergent or 15W-40 non-detergent oil.

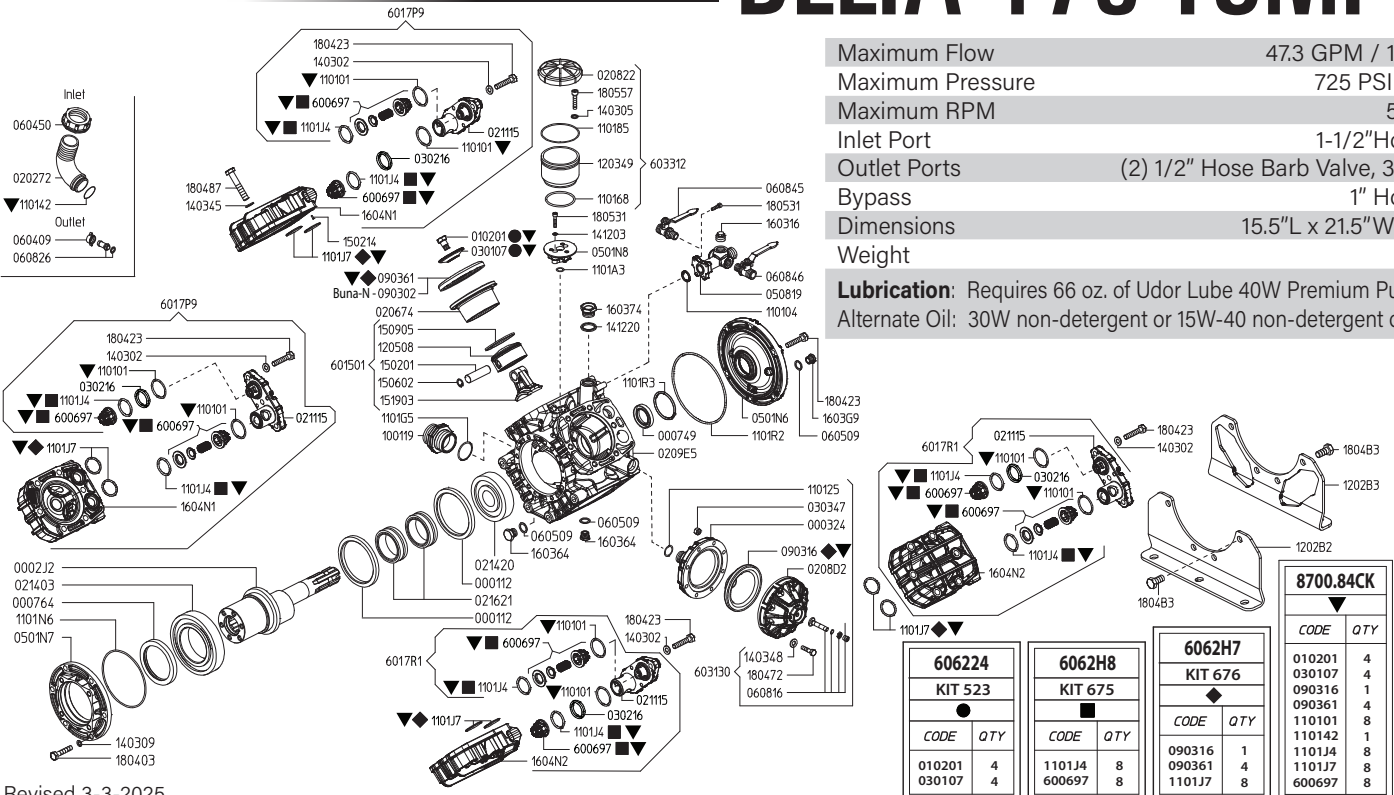

Revised 3-3-2025

Part #	Description	Qty
0001.12	RETAINER RING "DELTA 140/170"	2
0002.J2	SHAFT "DELTA 140/170" TS MFVA	1
0003.24	PRESSURE ACCUMULATOR	1
0007.49	OIL SEAL D35	1
0007.64	OIL SEAL D75	1
0102.01	DIAPHRAGM BOLT ●▼	4
0202.72	HOSE BARB D40	1
0206.74	SLEEVE "DELTA 140/170"	4
0208.22	OIL RESERVOIR COVER	1
0208.D2	ACCUMULATOR COVER	1
0209.E5	PUMP BODY	1
0211.15	VALVE COVER	4
0214.03	BALL BEARING D75	1
0214.20	BALL BEARING D35	1
0216.21	ROLLER BEARING D35	2
0301.07	DIAPHRAGM DISC ●▼	4
0302.16	SPACER	4
0303.47	HEX NUT M8X8	8
0501.N6	CRANKCASE FLANGE	1
0501.N7	CRANKCASE FLANGE - MFVA	1
0501.N8	FLANGE - OIL BOWL	1
0508.19	BALL VALVE FLANGE "DELTA 140/170"	1
0604.09	BRASS NUT G1/2	1
0604.50	BARB NUT G1-1/2"	1
0605.09	GASKET D17	3
0608.16	AIR VALVE ASSEMBLY	1
0608.26	HOSE BARB D13+GASKET	1
0608.45	BALL VALVE RIGHT	1
0608.46	BALL VALVE LEFT	1
0903.02	PISTON DIAPHRAGM 116MM BUNA-N	4
0903.16	ACCUMULATOR DIAPHRAGM ◆▼	1
0903.61	PISTON DIAPHRAGM 116MM GREENTECH ◆▼	4
1001.19	INLET NIPPLE	1
1101.01	O-RING - VALVE COVER ▼	8
1101.04	O-RING - BALL VALVE FLANGE	1
1101.25	O-RING - ACUMULATOR	1
1101.42	O-RING - INLET HOSE BARB ▼	1
1101.68	O-RING - OIL RESERVOIR	1
1101.85	O-RING - OIL RESERVOIR	1
1101.A3	O-RING - OIL RESERVOIR	1
1101.G5	O-RING - INLET NIPPLE	1
1101.J4	O-RING - VALVE ◆▼	8
1101.J7	O-RING - HEAD, VITON ◆▼	8
1101.N6	O-RING - CRANKCASE FLANGE	1
1101.R2	O-RING - CRANKCASE FLANGE	1

Part #	Description	Qty
1101.R3	O-RING - CRANKCASE FLANGE	1
1202.B2	BASE PLATE "DELTA 170"	1
1202.B3	BASE PLATE "DELTA 170"	1
1203.49	OIL RESERVOIR "BETA"	1
1205.08	ALUMINIUM PISTON D75	4
1403.02	WASHER D10.5	12
1403.05	WASHER D8.4	3
1403.09	WASHER D10.5	6
1403.45	WASHER D13	24
1403.48	WASHER D8.4 DACROMET	8
1412.03	WASHER	2
1412.20	WASHER	1
1502.01	PIN D18X64	4
1502.14	PIN	4
1506.02	SNAP RING D18	4
1509.05	PISTON RING D75	4
1519.03	CONNECTING ROD	4
1603.16	PLUG G1/2	1
1603.64	OIL PLUG	2
1603.74	PLUG	1
1603.G9	PLUG	1
1604.N1	RIGHT HEAD "DELTA 140/170"	2
1604.N2	LEFT HEAD "DELTA 140/170"	2
1804.03	HEX BOLT M10X30	6
1804.23	HEX BOLT M10X40	18
1804.72	HEX BOLT M8X50	8
1804.87	HEX BOLT	24
1804.B3	HEX BOLT	8
1805.31	ALLEN BOLT M6X30	6
1805.57	ALLEN BOLT	3
6006.97	VALVE ASSEMBLY W/O O-RING ■▼	8
6015.01	ROD ASSY "DELTA 140/170" D75	4
6017.P9	HEAD ASSEMBLY - RIGHT	2
6017.R1	HEAD ASSEMBLY - LEFT	2
6031.30	PRESSURE ACCUMULATOR ASSEMBLY	1
6033.12	OIL RESERVIOR ASSEMBLY	1
6062.24	DIAPHRAGM BOLT / WASHER KIT (KIT 523)	1
6062.H7	DIAPHRAGM KIT - GREENTECH (KIT 676)	1
6062.H8	IN/OUT VALVE KIT (KIT 675)	1
8700.84CK	COMPLETE REPAIR KIT	1

- Parts in 6062.24 (Kit 523)
- ◆ Parts in 6062.H7 (Kit 676)
- Parts in 6062.H8 (Kit 675)
- ▼ Parts in 8700.84CK (Complete Repair Kit)

8700.84CK	
CODE	QTY
010201	4
030107	4
090316	1
090361	4
110101	8
110142	1
1101J4	8
1101J7	8
600697	8

606224	
KIT 523	
CODE	QTY
010201	4
030107	4

6062H8	
KIT 675	
CODE	QTY
1101J4	8
600697	8

6062H7	
KIT 676	
CODE	QTY
090316	1
090361	4
1101J7	8

Adjustable Pressure Regulator

Maximum Flow	47.3 GPM / 179.2 lpm
Maximum Pressure	1200 PSI / 81 bar
Inlet Port	3/4" Male BSP
Outlet Ports	-
Bypass - Hose Barb	1" HB

606254	
KIT 553	
■	
CODE	QTY
090325	1
110101	1
110131	1
120413	1
150125	1
181001	1

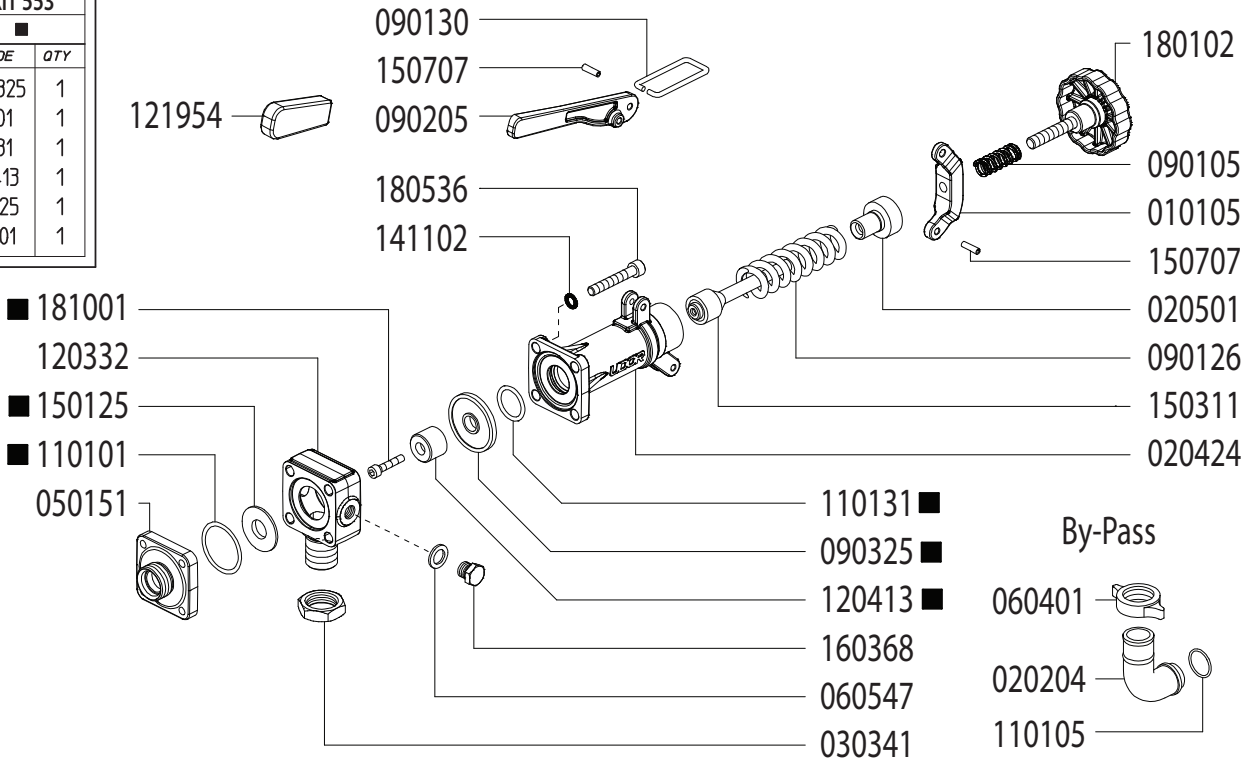

Revised 3-3-2025

Part #	Description	Qty
0101.05	LEVER GUIDE	1
0202.04	1" BRASS ELBOW HOSE BARB	1
0204.24	VALVE BODY	1
0205.01	VALVE CYLINDER	1
0303.41	NUT	1
0501.51	FLANGE	1
0604.01	BARB NUT	1
0605.47	GASKET D8	1
0901.05	SPRING	1
0901.30	PRESSURE BAIL	1
0901.26	SPRING	1
0902.05	HANDLE	1
0903.25 ■	DIAPHRAGM	1
1101.01 ■	O-RING - BYPASS FLANGE	1
1101.05	O-RING - BYPASS HOSE BARB	1

Part #	Description	Qty
1101.31 ■	O-RING - VALVE BODY	1
1203.32	INLET ELBOW - 3/4" MALE BSP	1
1204.13	POPPET ■	1
1219.54	HANDLE COVER - RUBBER	1
1501.25	SEAT ■	1
1503.11	REGULATOR STEM	1
1507.07	PIN	2
1603.68	PLUG - 1/4" BRASS	1
1801.02	ADJUSTMENT KNOB	1
1805.36	BOLT	4
1810.01	BOLT - STAINLESS STEEL ■	1
GG1500	HIGH PRESSURE GAUGE (OPTIONAL)	1
6062.54	REPAIR KIT (KIT 553)	

■ Parts Included in Repair Kit #6062.54 (KIT 553)

OPERATING INSTRUCTIONS

- Before operating or re-operating pump, lift R.V. Handle (0902.05) so pump will start at zero pressure.
FAILURE TO DO SO WILL VOID PUMP WARRANTY.
- Turn Pressure Adjustment Knob (1801.02) counter-clockwise to relieve spring tension. (Step 2 is only necessary on initial start-up and is not necessary for daily operation.)
- Start unit and let run until air is evacuated from system, when only liquid is expelled from the bypass line.
- Return R.V. Handle (0902.05) to down position. Open spray gun or spray boom and turn adjustment knob (1801.02) clockwise until desired operating pressure is achieved.

All Dimensions are WITHOUT Control Unit or Regulator

Dimensional Drawings are Shown in Millimeters. To Convert to Inches, Multiply Dimension x 0.03937

Specifications

DELTA 170

Inlet Port - Hose Barb	1-1/4" HB
Outlet Ports - Hose Barb	(2) 1/2" HB
Bypass - Hose Barb	3/4" HB
Dimensions	15.5" L x 21.5" W x 16.5" H
Diaphragm Material	GREENTECH (Std) Buna-N (Opt)

Lubrication: Requires 67 oz. of Udor Lube 40W Premium Pump Oil.
Alternate Oil: 30W non-detergent or 15W-40 non-detergent oil.

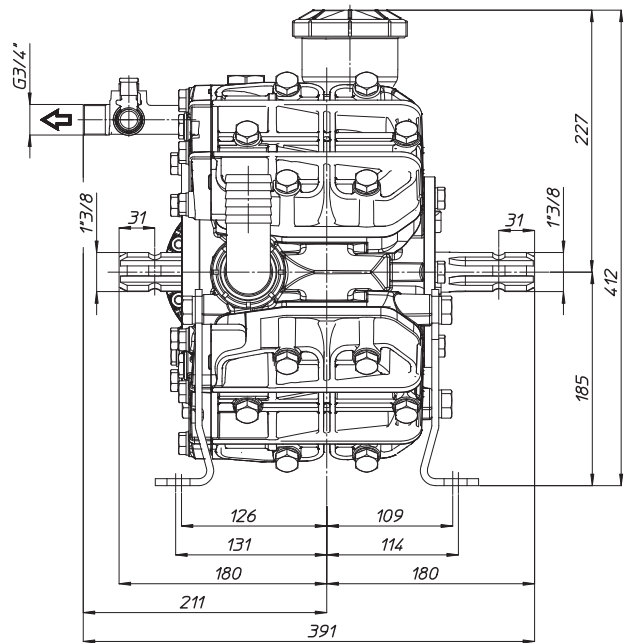
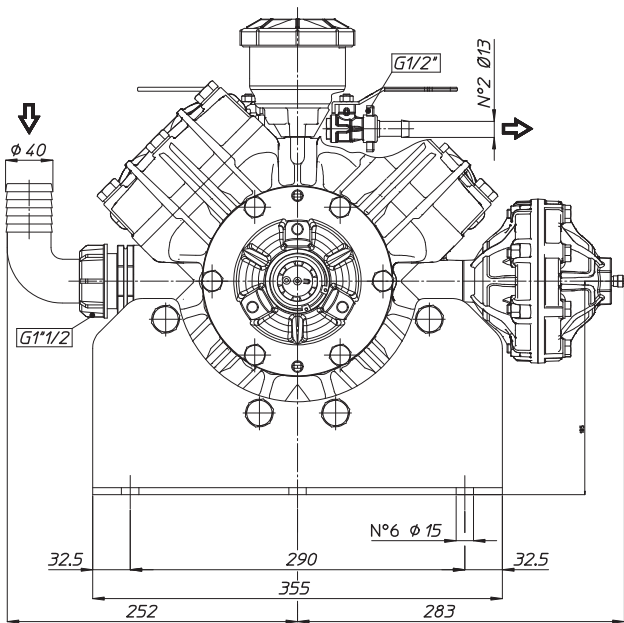

TORQUE SPECS

Ref.	Description	Ft./lb.	Nm
1	Diaphragm Bolts (Use Loctite 243)	23	30
2	Head Bolts	37	50
3	Pulsation Dampener Bolts	18	25
4	Inlet Flange Bolts	7	10
5	Bearing Flange Bolts	25	34
6	Oil Cup Bolts	7	10
7	Valve Cover Bolts	18	25

