

## 5-Cylinder, Medium-Pressure Diaphragm Pumps

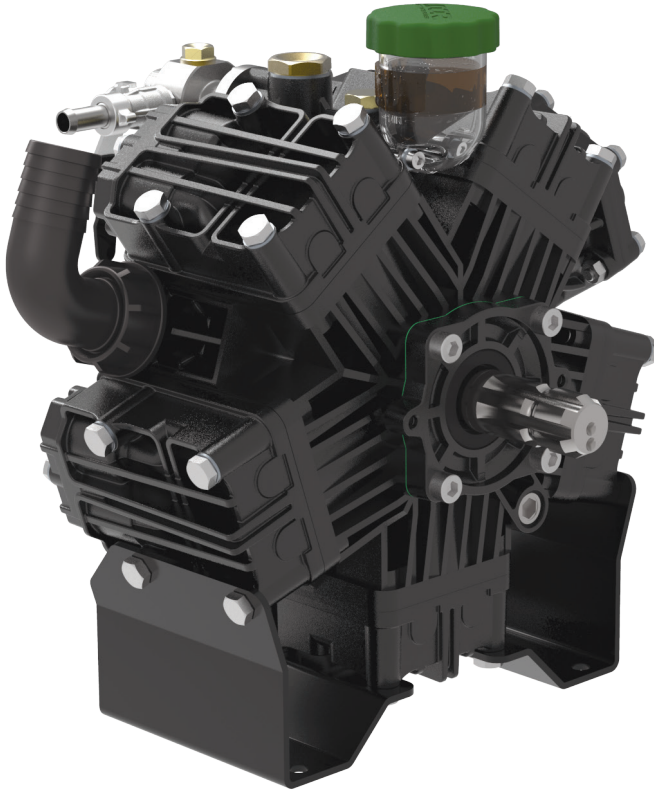

DELTA 125 5-cylinder, medium pressure diaphragm pumps are internally manifolded with anodized aluminum construction and anodized aluminum and stainless steel liquid handling parts.

DELTA 125 pumps are excellent choices for various horticultural, agricultural, lawn care, nursery, pest control and turf spraying applications. They are also effectively used for aircraft de-icing, hydrostatic testing and cleaning applications.

Model	GPM	l/min	PSI	bar	RPM	Drive Configuration	Weight
DELTA 125 1C	34.0	126.0	560	40	550	1-3/8" 6-Spline Male PTO Shaft	65 LBS
DELTA 125 VA	34.0	126.0	560	40	550	Universal VA Drive Face. Mounting Rails	65 LBS
DELTA 125 TSVA	34.0	126.0	560	40	550	Universal VA Drive Face x 1-3/8" 6-Spline Male PTO	65 LBS
DELTA 125 TS2C	34.0	126.0	560	40	550	1-3/8" 6-Spline Male PTO Thru-Shaft	65 LBS
DELTA 125 VAGR1	34.0	126.0	560	40	550	Gear Reduction for Gas Engines with 1" Shaft, 8-20 HP	85 LBS

Specifications	DELTA 125	Description	Part #
Inlet Port	1-1/4" Hose Barb	Diaphragm Kit (GREENTECH)	6062.F7
Outlet Ports	(2) 1/2" Hose Barb, 3/4" MBSP	Diaphragm Bolt / Washer Kit	6062.87
Bypass	3/4" Hose Barb	Valve Kit	6062.F8
Piston Diameter	60mm	Regulator Repair Kit	6062.53
Crankshaft Stroke/Code	170mm / G	Complete Repair Kit	8700.82CK
Dimensions	14.0"L x 18.0"W x 16.0"H		

**Lubrication:** Requires 69 oz. of Udor Lube 40W Premium Pump Oil.  
Alternate Oil: 30W non-detergent or 15W-40 non-detergent oil.



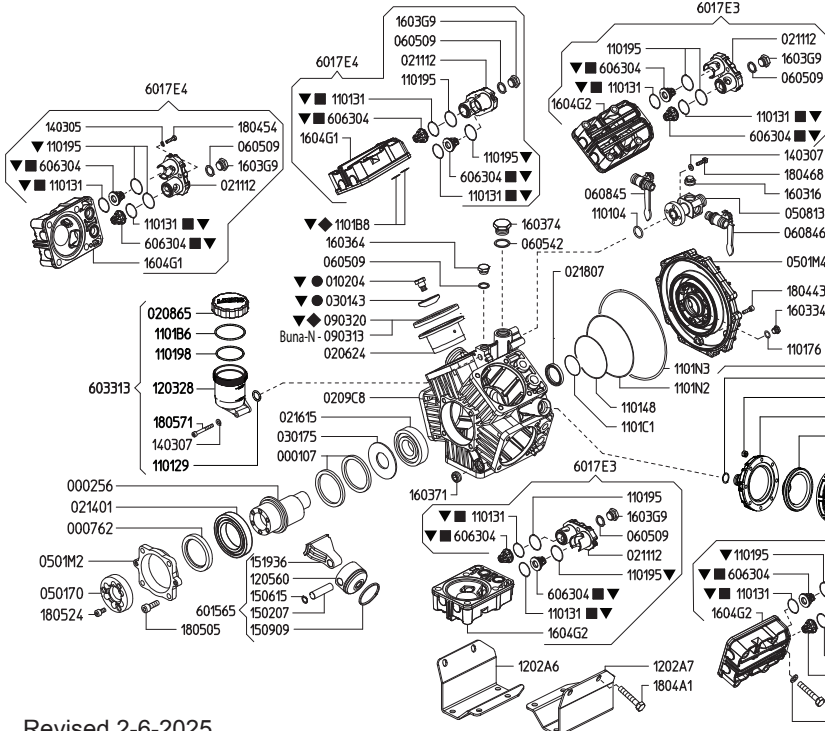

Maximum Flow	34.0 GPM / 126 lpm
Maximum Pressure	560 PSI / 40 bar
Maximum RPM	550 RPM
Inlet Port	1-1/2" Hose Barb
Outlet Ports	(2) 1/2" Hose Barb Valve, 3/4" MPT
Bypass	1" Hose Barb
Dimensions	14.0"L x 18.0"W x 16.0"H
Weight	46 lbs
<b>Lubrication:</b> Requires 69 oz. of Udor Lube 40W Premium Pump Oil. Alternate Oil: 30W non-detergent or 15W-40 non-detergent oil.	

**8700.82CK**

CODE	QTY
010204	5
030143	5
090316	1
090320	5
110104	1
110110	1
110131	10
110142	1
110195	10
110188	10
606304	10

**6062F7**  
KIT 658

CODE	QTY
090316	1
090320	5
110188	10

**6062F8**  
KIT 659

CODE	QTY
110131	10
606304	10

**606287**  
KIT 587

CODE	QTY
010204	5
030143	5

Revised 2-6-2025

Part #	Description	Qty
0001.07	RETAINER RING	2
0002.56	SHAFT "DELTA-100" VA	1
0003.24	PRESSURE ACCUMULATOR	1
0007.62	OIL SEAL D60	1
0102.04	DIAPHRAGM BOLT ●▼	5
0202.72	HOSE BARB D40	1
0206.24	SLEEVE D60	5
0208.65	OIL RESERVOIR COVER	1
0208.D2	PRESSURE ACCUMULATOR COVER	1
0209.C8	CRANKCASE	1
0211.12	VALVE COVER	5
0214.01	BALL BEARING D60	1
0216.15	ROLLER BEARING D35	1
0218.07	CAP D47X7	1
0301.43	DIAPHRAGM DISC ●▼	5
0301.75	BEARING DISC	1
0303.47	HEX NUT M8X8	8
0501.70	FLANGE "DELTA 75/100" VA	1
0501.M2	FLANGE "DELTA 75/100" VA	1
0501.M4	CRANKCASE FLANGE	1
0508.13	FLANGE G3/4 M - G3/8 F	1
0604.09	BRASS NUT G1/2	2
0604.50	BARB NUT G1-1/2"	1
0605.09	GASKET D17	6
0608.16	AIR VALVE ASSEMBLY	1
0608.26	HOSE BARB D13+GASKET	2
0608.45	BALL VALVE RIGHT	1
0608.46	BALL VALVE LEFT	1
0903.20	PISTON DIAPHRAGM D100 BUNA-N	5
0903.16	PRESSURE ACCUMULATOR DIAPHRAGM ■▼	1
0903.20	PISTON DIAPHRAGM D100 GREENTECH ■▼	5
1101.04	O-RING - DISCHARGE FLANGE	1
1101.25	O-RING - PRESSURE ACCUMULATOR	1
1101.29	O-RING - OIL RESERVOIR	1
1101.31	O-RING - VALVE ■▼	10
1101.42	O-RING - INLET HOSE BARB ▼	1
1101.48	O-RING - CRANKCASE FLANGE	1
1101.76	O-RING - PLUG	1
1101.95	O-RING - VALVE COVER ▼	10
1101.98	O-RING - OIL RESERVOIR	1
1101.B6	O-RING - OIL RESERVOIR	1
1101.B8	O-RING - HEAD ◆▼	10
1101.C1	O-RING - CRANKCASE FLANGE	1

Part #	Description	Qty
1101.N2	O-RING - CRANKCASE FLANGE	1
1101.N3	O-RING - CRANKCASE FLANGE	1
1202.A6	LEFT BASE PLATE	1
1202.A7	RIGHT BASE PLATE	1
1203.28	OIL RESERVOIR	1
1205.60	ALUMINIUM PISTON D60	5
1403.05	WASHER M8	10
1403.07	WASHER M6	6
1403.09	WASHER M10	16
1403.48	WASHER M8	8
1502.07	PIN D15X54	5
1506.15	SNAP RING D15	5
1509.09	PISTON RING D60	5
1519.36	CONNECTING ROD	5
1603.16	PLUG G1/2	1
1603.34	PLUG G1/4	1
1603.64	PLUG G3/8	1
1603.71	PLUG G1/2	1
1603.G9	HEAD PLUG 3/8	5
1604.G1	RIGHT HEAD	2
1604.G2	LEFT/BOTTOM HEAD	3
1804.43	HEX BOLT M6X35	10
1804.54	HEX BOLT M8X35	10
1804.68	HEX BOLT M6X22	4
1804.72	HEX BOLT M8X50	8
1804.A1	HEX BOLT M10X70	20
1805.05	ALLEN BOLT M10X30	4
1805.24	ALLEN BOLT M8X16	3
1805.71	ALLEN BOLT M6X50	2
6015.65	ROD ASSY D60	5
6017.E3	HEAD ASSEMBLY - LEFT/BOTTOM	3
6017.E4	HEAD ASSEMBLY - RIGHT	2
6031.30	PRESSURE ACCUMULATOR ASSEMBLY	1
6033.13	OIL RESERVOIR ASSEMBLY	1
6063.04	VALVE ASSEMBLY W/O O-RING ◆▼	10
6062.87	DIAPHRAGM BOLT/WASHER KIT (KIT 587)	1
6062.F7	DIAPHRAGM KIT - GREENTECH (KIT 658)	1
6062.F8	IN/OUTLET VALVE KIT(KIT 659)	1
8700.82CK	COMPLETE REPAIR KIT	1

- Parts in 6062.87 (Kit 587).
- Parts in 6062.F7 (Kit 658).
- ◆ Parts in 6062.F8 (Kit 659).
- ▼ Parts in 8700.82CK (Complete Repair Kit).

**6.25:1 GAS ENGINE GEAR REDUCTION FOR  
DELTA 100/125/140 DIAPHRAGM PUMPS  
on GAS ENGINES with 1" SHAFTS  
REQUIRES 28 OZ. 90W GEAR LUBE**

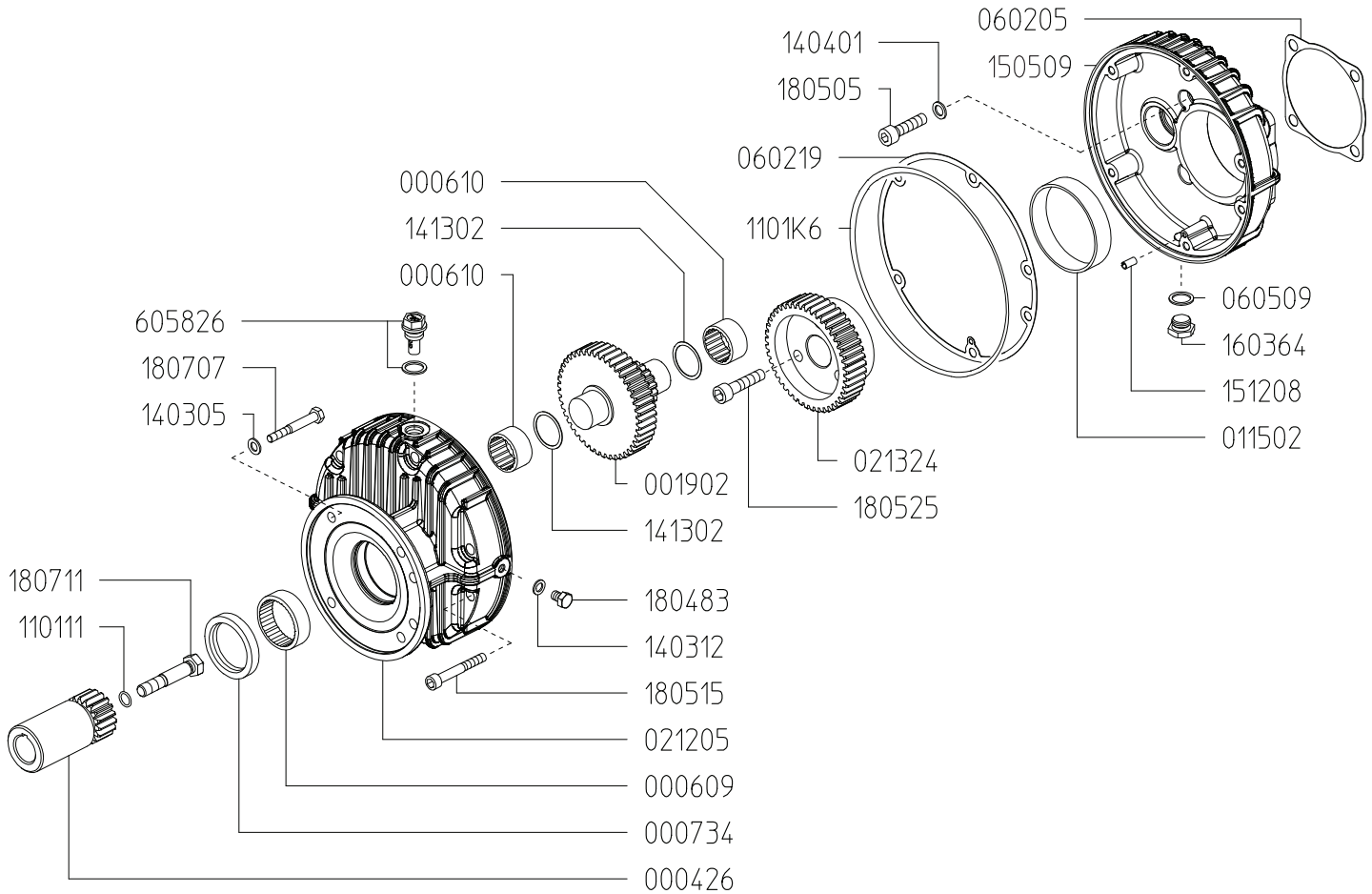

Revised 3-6-2024

Part #	Description	Qty	Part #	Description	Qty
0004.26	GEAR SHAFT "S162-1"VA"	1	1403.05	WASHER D8.4	4
0006.09	BUSHING D45	1	1403.12	GASKET D8.5	1
0006.10	BUSHING D30	2	1413.02	WASHER D30	2
0007.34	OIL SEAT D45	1	1505.09	GEAR BODY "S162"	1
0019.02	GEAR SHAFT "S162"	1	1512.08	PIN - D4X16	1
0115.02	BUSHING D80 GLY	1	1603.64	PLUG G3/8	1
0212.05	REDUCER COVER "S162"	1	1804.83	HEX BOLT M8X12	1
0213.24	RED.GEAR WHEEL Z=45 "S162-VA"	1	1805.05	ALLEN BOLT M10X30	4
0602.05	GASKET	1	1805.15	ALLEN BOLT M8X60	6
0602.19	GASKET "S162"	1	1805.25	ALLEN BOLT M10X45	3
0605.09	GASKET D17	1	1807.07	HEX BOLT 5/16X1" UNF	4
0605.41	GASKET D10	4	1807.11	HEX BOLT 7/16"X2" UNF	1
1101.11	O-RING - GEAR SHAFT	1	6058.26	OIL PLUG G3/8	1
1101.K6	O-RING - COVER/BODY	1			

## Adjustable Pressure Regulator

Maximum Flow	47.3 GPM / 179.2 lpm
Maximum Pressure	1200 PSI / 81 bar
Inlet Port	3/4" Male BSP
Outlet Ports	-
Bypass - Hose Barb	1" HB

<b>606254</b>	
<b>KIT 553</b>	
■	
<b>CODE</b>	<b>QTY</b>
090325	1
110101	1
110131	1
120413	1
150125	1
181001	1

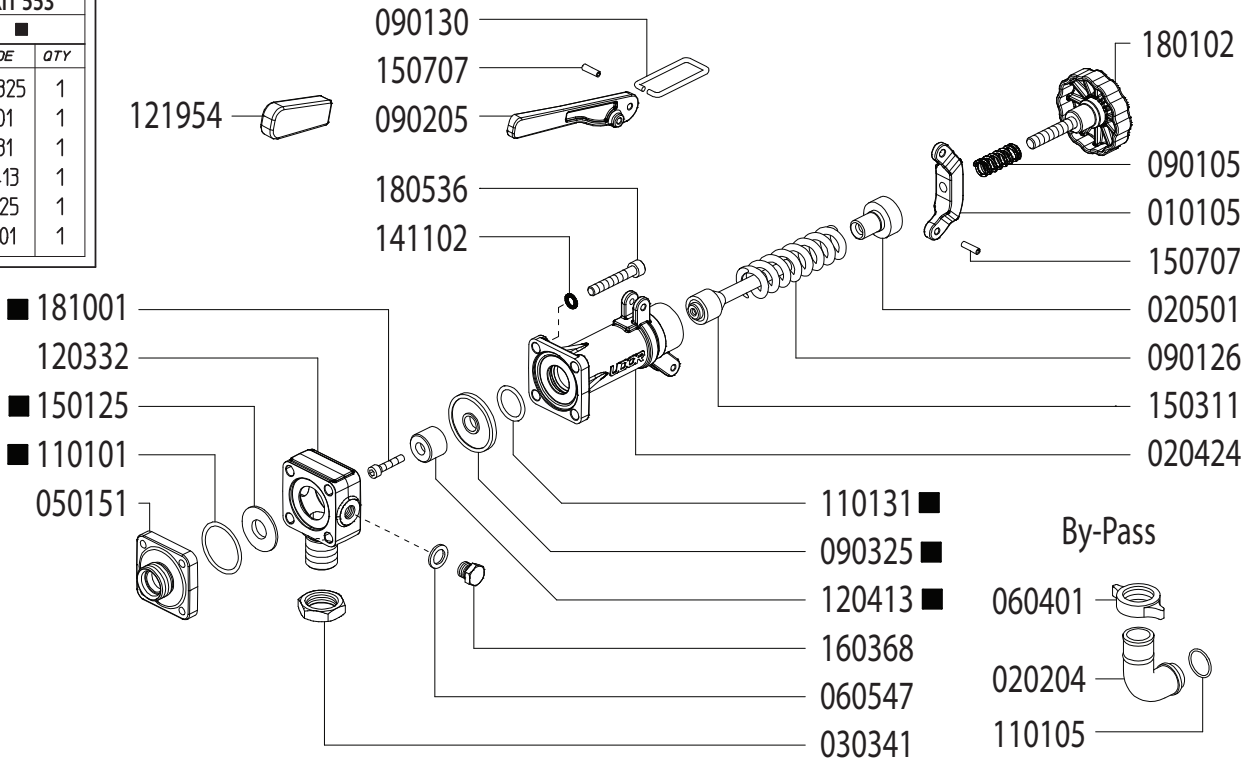

Revised 2-6-2025

Part #	Description	Qty
0101.05	LEVER GUIDE	1
0202.04	1" BRASS ELBOW HOSE BARB	1
0204.24	VALVE BODY	1
0205.01	VALVE CYLINDER	1
0303.41	NUT	1
0501.51	FLANGE	1
0604.01	BARB NUT	1
0605.47	GASKET D8	1
0901.05	SPRING	1
0901.30	PRESSURE BAIL	1
0901.26	SPRING	1
0902.05	HANDLE	1
0903.25 ■	DIAPHRAGM	1
1101.01 ■	O-RING - BYPASS FLANGE	1
1101.05	O-RING - BYPASS HOSE BARB	1

Part #	Description	Qty
1101.31 ■	O-RING - VALVE BODY	1
1203.32	INLET ELBOW - 3/4" MALE BSP	1
1204.13	POPPET ■	1
1219.54	HANDLE COVER - RUBBER	1
1501.25	SEAT ■	1
1503.11	REGULATOR STEM	1
1507.07	PIN	2
1603.68	PLUG - 1/4" BRASS	1
1801.02	ADJUSTMENT KNOB	1
1805.36	BOLT	4
1810.01	BOLT - STAINLESS STEEL ■	1
GG1500	HIGH PRESSURE GAUGE (OPTIONAL)	1
6062.54	REPAIR KIT (KIT 553)	

■ Parts Included in Repair Kit #6062.54 (KIT 553)

### OPERATING INSTRUCTIONS

- Before operating or re-operating pump, lift R.V. Handle (0902.05) so pump will start at zero pressure.  
**FAILURE TO DO SO WILL VOID PUMP WARRANTY.**
- Turn Pressure Adjustment Knob (1801.02) counter-clockwise to relieve spring tension. (Step 2 is only necessary on initial start-up and is not necessary for daily operation.)
- Start unit and let run until air is evacuated from system, when only liquid is expelled from the bypass line.
- Return R.V. Handle (0902.05) to down position. Open spray gun or spray boom and turn adjustment knob (1801.02) clockwise until desired operating pressure is achieved.

