

Direct Drive, Gas Engine Flange Models

1" Hollow Shaft, SAE J609-B Flange and Set Screw
3400 RPM

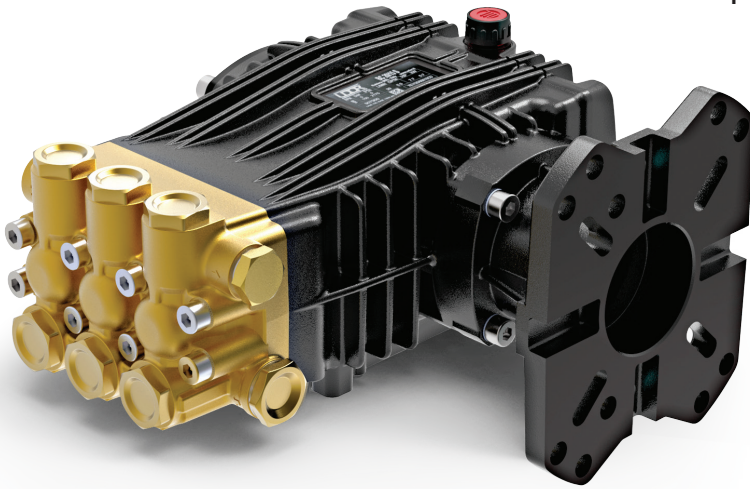

- Brass Manifold
- Heat Treated Crankshaft
- Stainless Steel Piston Guides
- High Strength Aluminum Alloy Connecting Rods
- Industrial Quality Tapered Roller Bearings
- Solid Ceramic Plungers
- Stainless Steel Check Valves
- Heavy Duty Flat Base High Pressure Seals
- Replaceable PTFE Coated Body Guides
- 15.4 oz. Capacity Vented Oil Bath Crank Case
- 1/2" BSP-F Inlet. 3/8" BSP-F Outlet
- Max Fluid Temp, 160°F

BL Series Direct Drive, Gas Engine Flange Plunger Pumps

BL Series standard duty plunger pumps include a wide range of models with flow rates from 4.1 to 5.0 GPM and pressures up to 2900 PSI.

Other drive options include 24mm solid shaft, electric motor flange, gas engine gear reduction and hydraulic motor flange.

Applications include general pressure cleaning, sewer jetting, vehicle wash equipment and fire fighting applications.

	Model	Flow		Pressure		Plunger Dia.	Crankshaft		Power	Seal Kit	Valve Kit	Wt.
		GPM	l/min	PSI	bar		Stroke	Code				
3400 RPM	BL 4.0/30 W	4.1	15.5	2900	200	15mm	10.0mm	5	11 HP Gas	6061.B2	6061.02	23 lbs
	BL 5.0/30 W	5.0	19.0	2900	200	15mm	12.0mm	6	14.5 HP Gas	6061.B2	6061.02	23 lbs

NOTE: All pump models available with left-hand drive option. Add 'L' to model number when ordering (ex. BL 5.0/30 WL)



MAX FLOW
MAX PRESSURE
RATED PUMP SPEED
POWER REQUIREMENT
LUBRICATION

4.1 GPM / 15.5 L/MIN
2900 PSI / 200 BAR
3400 RPM
11.0 HP GAS ENGINE
15.4 OZ UDOR LUBE

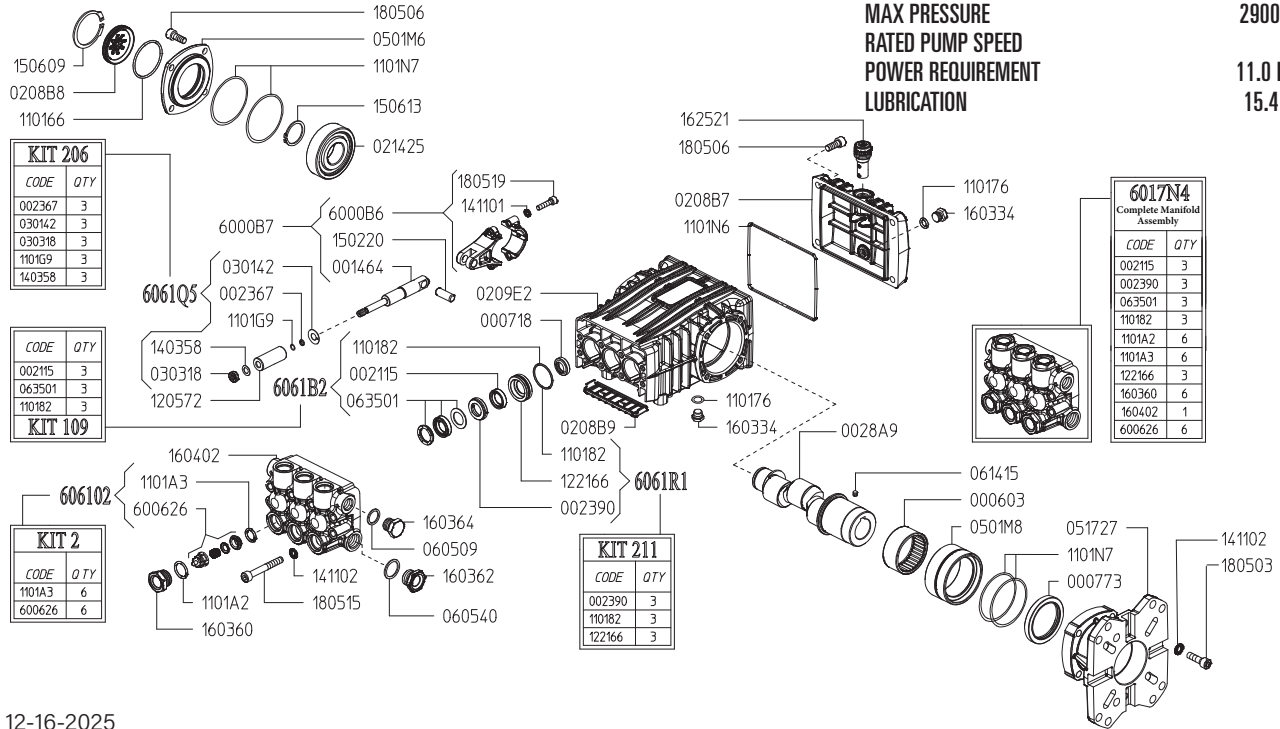

Revised 12-16-2025

Part #	Description	Qty	Part #	Description	Qty
0006.03	BUSHING D50	1	1205.72	CERAAMIC PLUNGER D15 "B/BK"	3
0007.18	OIL SEAL D15X24X5	3	1221.66	PRESSURE RING D15 "B/BK" ^{D E}	3
0007.73	OIL SEAL D50	1	1403.58	WASHER D8 ^C	3
0014.64	PLUNGER GUIDE "B/BK"	3	1411.01	SERATED WASHER D6	6
0021.15	WATER SEAL LP D15X22X5.7 ^{B E}	3	1411.02	SERATED WASHER D8	12
0023.67	RING D5.2X8X1.3 ^C	3	1502.20	PIN D10X27	3
0023.90	UPPER RING D15 "B/BK" ^{D E}	3	1506.09	SNAP RING D52	1
0028.A9	HOLLOW SHAFT "B/BK" D1"	1	1506.13	SNAP RING D30	1
0208.B7	BACK COVER "B/BK"	1	1603.34	PLUG G1/4	2
0208.B8	OIL SIGHT GLASS	1	1603.60	VALVE PLUG D15/18/20 ^E	6
0208.B9	COVER "B/BK"	1	1603.62	PLUG G1/2	1
0209.E2	CRANKCASE "B-X/BK-X"	1	1603.64	PLUG G3/8	1
0214.25	BEARING D30	1	1604.02	HEAD "B-X" ^E	1
0301.42	SLINGER RING ^C	3	1625.21	OIL PLUG G3/8	1
0303.18	NUT M8XH5 ^C	3	1805.03	ALLEN BOLT M8X30	4
0501.M6	BEARING FLANGE "B/BK"	1	1805.06	ALLEN BOLT M8X20	8
0501.M8	BEARING FLANGE "B/BK"	1	1805.15	ALLEN BOLT M8X60	8
0517.27	ENGINE FLANGE "B/BK" HP7/18	1	1805.19	ALLEN BOLT M6X25	6
0605.09	GASKET D17X23X1.5	1	6000.B6	CONNECTING ROD "B/BK"	3
0605.40	GASKET D21.5X27X1.5	1	6000.B7	COMPLETE CONNECTING ROD ASS'Y "B/BK"	3
0614.15	SET SCREW M5X8	1	6006.26	VALVE ASSEMBLY WITHOUT O-RING ^{A E}	6
0635.01	HIGH PRESSURE SEAL KIT D15 ^{B E}	3	6017.N4	COMPLETE MANIFOLD ASSEMBLY	1
1101.66	O-RING - OIL SIGHT GLASS	1	6061.02	KIT 2 - VALVE KIT "PK/M/B"	1
1101.76	O-RING - PLUG	2	6061.B2	KIT 109 - WATER SEAL KIT	1
1101.82	O-RING - PRESSURE RING ^{B D E}	3	6061.Q5	KIT 206 - PLUNGER KIT D15/18 "B/BK"	1
1101.A2	O-RING - VALVE PLUG ^E	6	6061.R1	KIT 211 - BRASS RING KIT D15 "B/BK"	1
1101.A3	O-RING - VALVE ^{A E}	6			
1101.G9	O-RING - PLUNGER ROD ^C	3			
1101.N6	O-RING - BACK COVER	1			
1101.N7	O-RING - BEARING FLANGE	4			

A Parts in 6061.02 (Kit 2).
B Parts in 6061.B2 (Kit 109).
C Parts in 6061.Q5 (Kit 206).
D Parts in 6061.R1 (Kit 211).
E Parts in 6017.N4 (Complete Manifold Assembly).

WEIGHT
LUBRICATION

23 LBS
15.4 OZ UDOR LUBE

*Dimensional Drawings are
Shown in Millimeters.
To Convert to Inches,
Multiply Dimension x 0.03937*

B SERIES PUMPS - 1" HOLLOW SHAFT w/ GAS ENGINE FLANGE

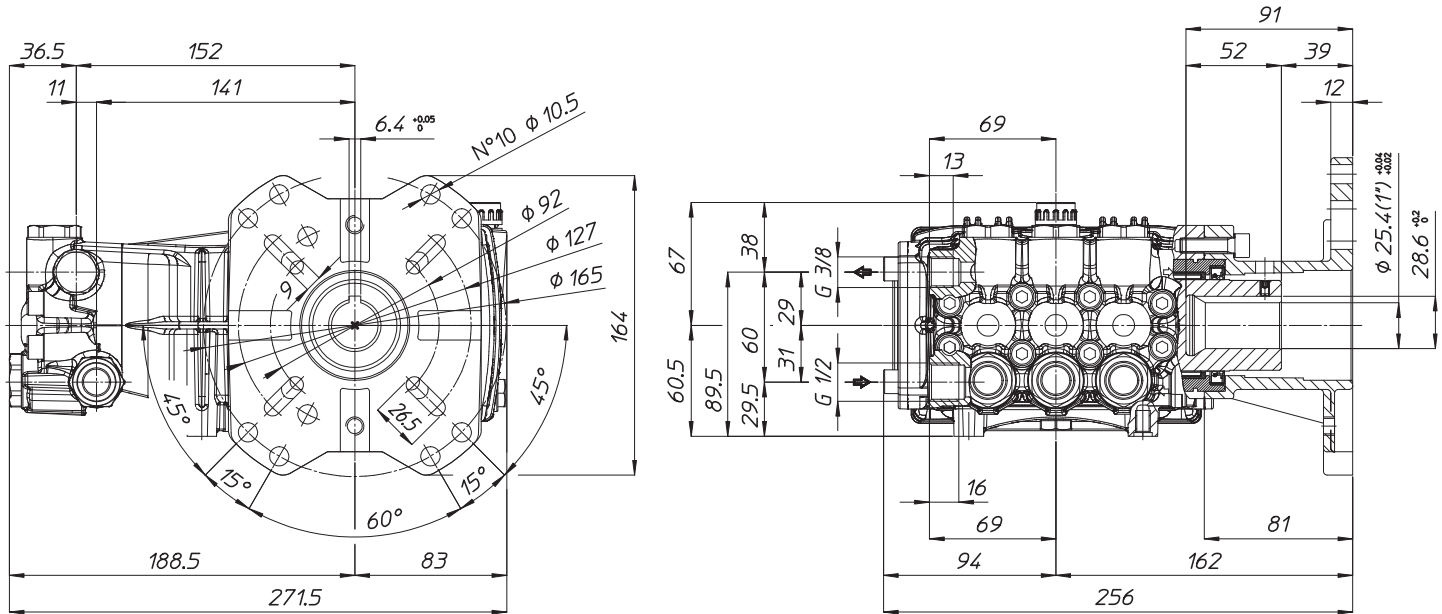

TORQUE SPECS

Ref.	Description	Ft./lb.	Nm	Loctite®
1	Head Bolts	19	25	-
2	Valve Caps	75	100	243
3	Inlet Cap	75	100	243
4	Outlet Cap	60	80	243
5	Bearing Flange Bolts	19	25	-
6	Rear Cover Bolts	19	25	-
7	Connecting Rod Bolts	9	11	243
8	Plunger Bolts	11	15	270
9	Valve Cover Bolts	-	-	-
10	Oil Drain Plug	19	25	-

